

ColourLED RGB LED Strip Specifications & Installation Guide

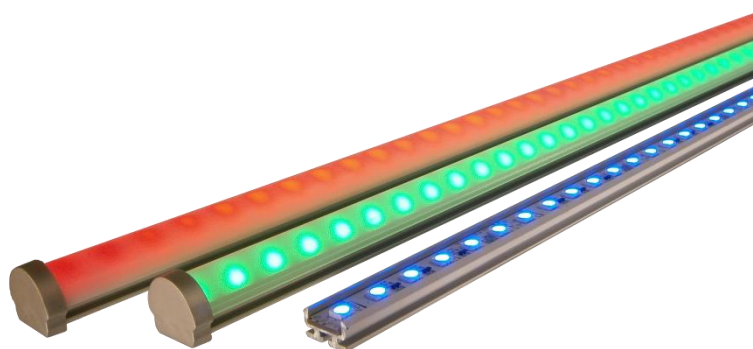

Table Of Contents

Safety Notes	2
Inputs	2
Optical	2
Javelin Covers	3
Dimensions	3
Javelin Extrusion	3
Installation	4
Mounting	4
Mounting the Javelin Extrusion	4
Wiring	4
Maintenance	4

Safety Notes

- Do not press On LEDs when installing
- Do not overflex strips
- Installation should only be performed by a qualified professional
- Install in accordance with all appropriate wiring standards
- Never connect a LED fitting to a driver that is powered. Doing so may result in damage to the LED.
- Always make sure the output voltage range and output current of the LED driver match the requirements of the LED fitting. Failure to do so may result in damage both the driver and fitting.

Inputs

			Units
Voltage	Nominal	24	
	Min	23	
	Absolute Maximum	25	
Drive Current	Per Colour	160	mA/m
	Total	480	
Watts	Per Colour	3.84	W/m
	Total	11.52	
Maximum run from power connection		4	m

Optical

	Red	Green	Blue	Combined	Units
Beam Angle	110				°
Wavelength	620 – 630	520 – 535	465 - 475		nm
Typical Lumens	57.6	130.4	38.4	226	lm/m

Javelin Covers

Stock Code	Description	Effect
O	Opal Diffuser	Solid white cover to create the smoothest linear effect
F	Frosted Diffuser	Semi-transparent cover
C	Clear	Transparent Cover
30	Clear 30° Linear Lens	Lens focusing light at 30° along length axis
60	Clear 60° Linear Lens	Lens focusing light at 60° along length axis
90	Clear 90° Linear Lens	Lens focusing light at 90° along length axis

Dimensions

All dimensions in mm

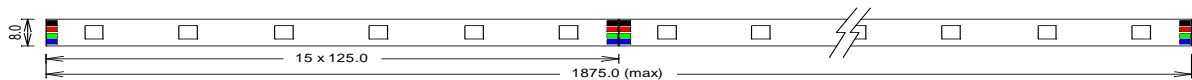

Extrusion must be 10mm longer than LED strip
 Maximum extrusion length is 2m

Javelin Extrusion

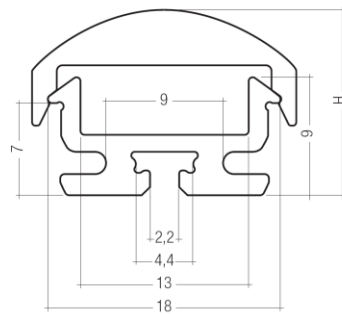

Javelin Extrusion (shown with Lens)

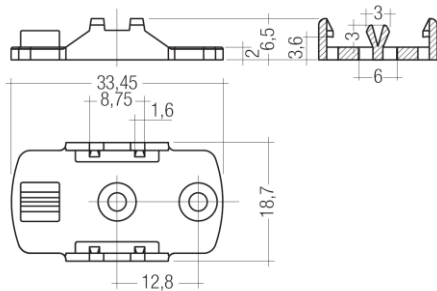

Javelin Mounting Clip

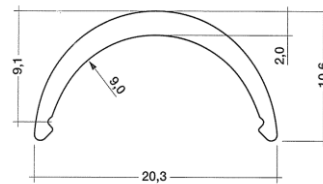

Javelin Cover/Diffuser

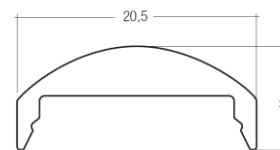

Lens	H
30°	11
60°	10
90°	9

Javelin Linear Lens

Installation

Mounting

- Do not install where water or high humidity may be present without further protection. Note that the Javelin extrusion is **NOT** sealed.
- Do not mount with the components or board touching any flammable surfaces.
- Do not install under mechanical stress
- Allow for expansion due to changes in temperature.
- Please be aware that while the system has a very long operational life, faults may still occur and provision needs to be made for maintenance.

Mounting the Javelin Extrusion

To mount the Javelin extrusion, simply screw the mounting clips to the surface, and then push the extrusion into the clips.

Recommended Screw: M2.5 screws
or
Self tapping screws with a diameter of 2.2 to 2.9mm and a screw head height of no more than 2.2mm

1 clip for every 0.5m of extrusion required. Minimum of 2 clips.

Wiring

- No continuous run of strips should exceed the specified maximum run value without additional power feeds.
- Only join strips powered by the same supply

Maintenance

- Strips normally require no maintenance except for cleaning
- Isolate from power before accessing
- Visually inspect strips at the time for any obvious faults
- The strips may be dusted with a non-conductive brush. No fluids should be used
- If this procedure does not remove contaminants please contact Digilin for further advice.